

SMART SWITCH TECHNOLOGIES



SmartSwitch *Yacht-Guard* Model SMS-8 Vessel System Monitor Installation Manual

SmartSwitch *Yacht-Guard*

Table of Contents

Features	3
Connections	4
System	5
Outputs	6
Inputs	7
COMMANDS	
Getting Started – Setting Up Initial Owner	8
Adding a Master	9
Removing a Master	9
Get a list of all the Masters	10
Turn All Texts OFF and Disable Inputs	10
Turn All Texts ON and Enable Inputs	10
Resetting Unit	10
Get a List of the Inputs	10
Get a List of the Outputs	11
Check Power Supply Voltage	11
Naming Inputs/Outputs and Changing Names	11
Turn an Output ON or OFF	11
Change the Input Delays	12
Change Input to Normally Open or Normally Closed	12
Set Input as a latched Input	12
Set Input as a non-latched Input	12
Reset latched Input	13
Link an Input to an Output	13
Make an Output Pulse On and Off	13
Make an Output Pulse On and Off (Continued)	14
Clear Output Pulse (Set to non-pulsed)	14
Change Battery Alarm for 12v or 24v Systems	14
Reset Battery Alarm	15
Get Firmware Version	15
Reset Unit to Factory Defaults	15
Warranty	16
<u>Appendix One</u>	
Table of User Selected Input and Output Names	17
Trouble Shooting Guide	18
<u>Appendix Two</u>	
SMS-8 Application Notes	19
SMS-8 Application Notes (Continued)	20
SMS-8 Application Notes (Continued)	21

Features - *Yacht-Guard Model SMS-8*

- Receive text messages on your cell phone alerting you to potential problems on your boat
- Send commands to control lights, pumps, appliances, air conditioning, etc. via text message from your cell phone
- Connects to most GSM networks world-wide
 - In the USA, GSM providers include AT&T and T-Mobile, and in Canada providers include Rogers Wireless
- Up to 12 cell phones may be designated as “masters” to send commands and receive alert text messages
- All set-up and changes made by texting (no need for a computer)
- Control up to four (4) devices using text message commands
- Monitor up to eight (8) devices that use switched contacts (switching Inputs which use contacts that open or close upon activation such as a bilge float switch):
 - Four Inputs Positive switching to battery +
 - Four Inputs Negative switching to ground -
 - Programmable Input delays (max 15 minutes)
 - Programmable for Latching or Non-Latching Inputs
 - Programmable for Normally Open or Normally Closed Inputs
- Inputs and Outputs names are user programmable via text command – up to 25 characters and multiple words
- Link any Input to any Output (Example: Link intruder sensor or smoke detector [input] to light or alarm horn [output])
- Monitors vessel battery supply voltage and sends alarm message if low battery is detected at 11.5 vdc (12v system) or 22.5 vdc (24v system)
- On-demand updates via text message to interrogate status of:
 - Current battery voltage
 - Status of all Inputs
 - Status of all Outputs
 - List of all designated “masters”
- Compact Size for wall or horizontal surface mounting:
 - 117mm x 78mm x 30mm

Monitor:

- Shore power disconnect
- Bilge pumps running
- High water alarms
- Motion sensors
- Door switches
- Pressure pads
- And much, much more

Control:

- Battery charger
- Fridge
- Freezer
- Under water lights
- Security alarms
- Or any device

Connections

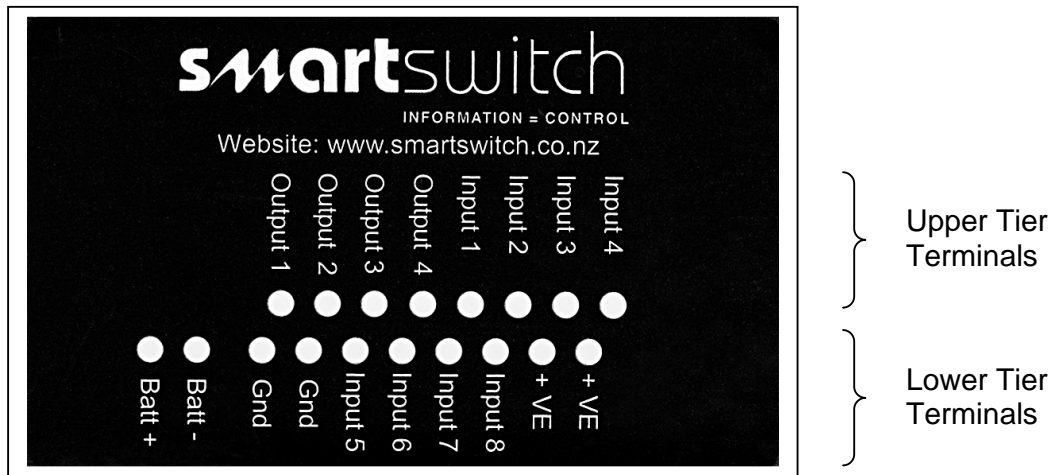

SMS-8 Terminal Electrical Specifications

Batt + = Battery positive 10 to 30vdc
 Batt - = Battery negative
 Outputs = sink max 400 Ma each
 Positive Inputs (Inputs 1, 2, 3 & 4) max Input voltage = 36vdc

Lower Tier Terminals

GND = Battery negative
 GND = Battery negative

Input 5 = Negative switching Input
 Input 6 = Negative switching Input
 Input 7 = Negative switching Input
 Input 8 = Negative switching Input

+ VE Positive out (for switch)
 + VE Positive out (for switch)

Upper Tier Terminals

Output 1
 Output 2
 Output 3
 Output 4

Input 1 = Positive switching Input
 Input 2 = Positive switching Input
 Input 3 = Positive switching Input
 Input 4 = Positive switching Input

System

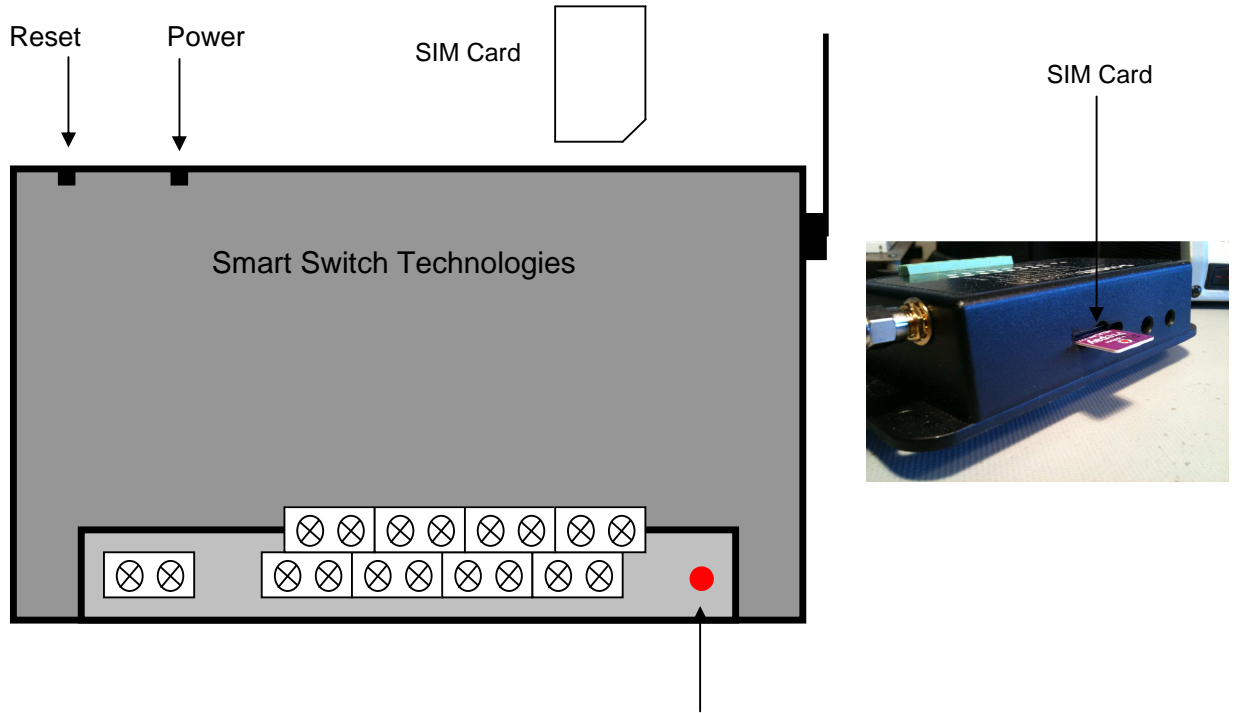

Signal LED:

Signal LED

If the LED flashes once every 1 second, this indicates the cellular network cannot be found (out of GSM coverage range). Remedy = Re-locate the device or use a longer aerial or signal booster.

If the LED flashes once every 3 seconds, this indicates the cellular network has been found (all ok).

Electrical Specifications:

Supply Voltage	12 to 30 Volts DC (Auto-Sensing)
Quiescent Current	20 Milli-amps
Data Retention	10 years (without power)
Outputs	Sink max 400 Ma each
Positive Input max Input voltage	36vdc

Outputs

The SMS-8 has four (4) Outputs. The Outputs are open collector rated at 400ma (max) and will short to GND when turned on. Therefore a Relay may need to be used for some applications.

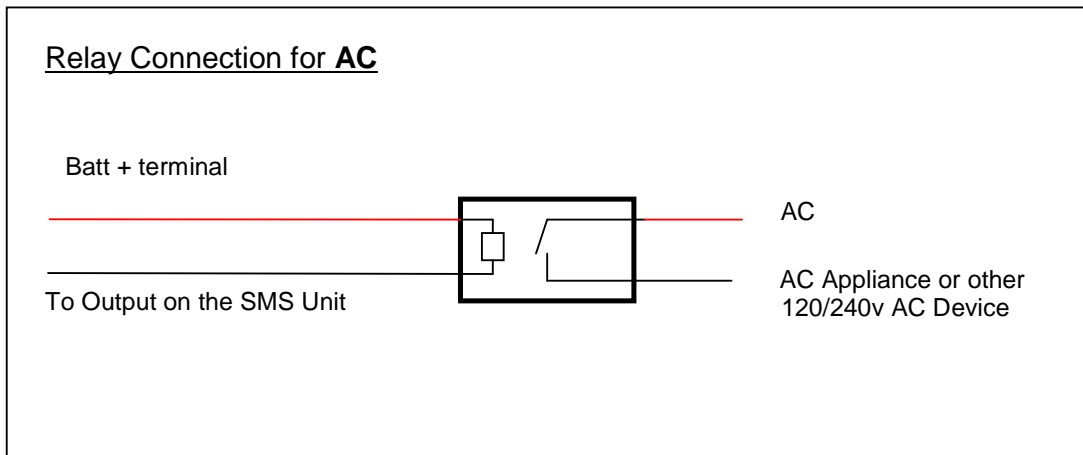
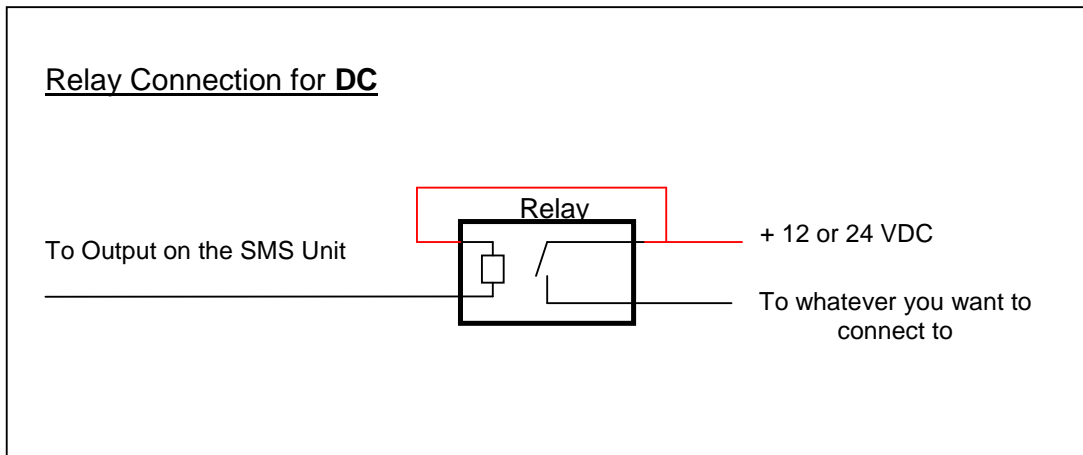

!! Important Note !!

A registered electrician must be used when connecting to the 120/240v main supply voltage.

Inputs

The SMS-8 has eight (8) Inputs. Four are Positive switching (to Battery+ or VE+) and four are Negative switching (to Ground -). **Note:** Two Battery+ (or VE+) and two Ground- (Gnd) terminals are provided on the SMS-8 for convenience. However, any battery or ground on the vessel common to the SMS battery power supply can be used for connection.

Positive switching: Inputs 1 - 4

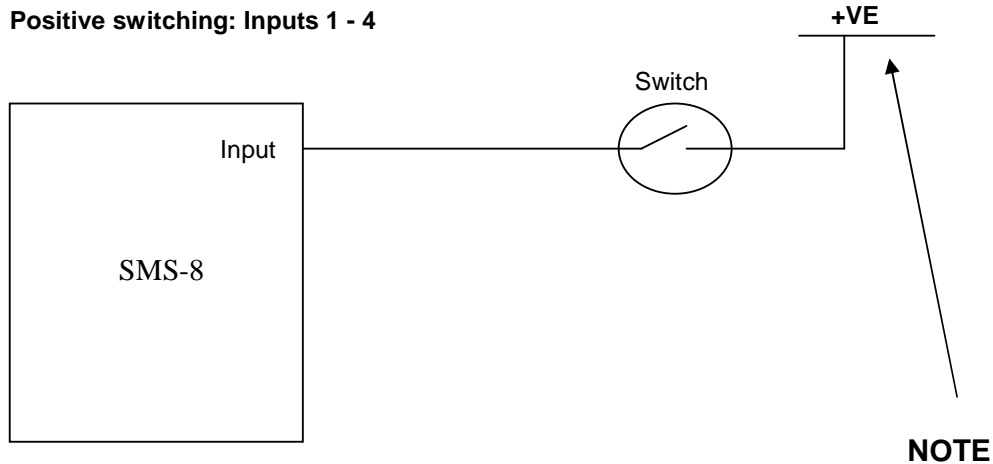

Negative switching: Inputs 5 - 8

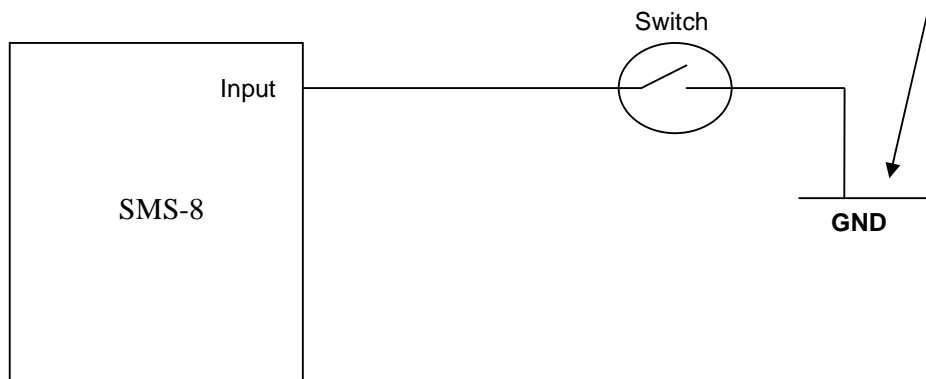

!! IMPORTANT !!

Setting up system for the first time:

Please ensure the SIM card has been ACTIVATED with the network provider, insert into SIM slot on the back (see page 5) and power the unit up.

When the unit is first powered ON a mobile (cell phone) number must be set for initial programming. This phone number is called the "Initial Owner".

Note: This could be the installer who would in turn add other users (Master add - see page 9) and set the system up. The installer would then remove his own number (Master remove - see page 9).

IMPORTANT: For all text commands, spelling and spaces must be strictly followed.

Setting up Initial Owner

Command: Set owner +??XXXXXXXX

?? Is the country code and XXXXXXXXX is the mobile number without the preceding 0.

Examples:

New Zealand = 64 (+64 and the number without the preceding 0)

If the users number is 0211893070 then Command = Set owner +64211893070

Australia = 61 (+61 and the number without the preceding 0)

If the users number is 0412882900 then Command = Set owner +61412882900

Singapore =0065 (+65 and the number without the preceding 0)

If the users number is 0412882900 then Command = Set owner +65412882900

USA & Canada = 001 (+1 and the Area Code & Number)

If the users number is 412-555-1234 then Command = Set owner +14125551234

When the Initial Owner setup has been successful you will receive the text message:

Your number has just been set as the systems master number

!! NOTE !!

If a Master sends a text message to the system, which is not an exact match with the commands, the system responds with:

Sorry either that device does not exist or the message format is not understood, please check the spelling and try again

If anyone other than a Master sends a text message to the system, the system responds with:

Sorry you are not permitted to access this device

Commands

Adding a Master

Command: Master add +??XXXXXXXX (Follow the same rules for Phone ID as for “Set Owner”)

If the master is already in the list, the system responds with:

Sorry +??XXXXXXXX is already active and cannot be added twice, please check the number and try again

If the number does not fit the checks, to confirm it is a valid number (all digits must be numbers excluding the leading +), the system responds with:

+??XXXXXXXX does not appear to be a valid number, please check that there are no letters or symbols in the number and try again

If the number does not lead with a +, the system responds with:

??XXXXXXXX does not appear to have the country code in international format (e.g. +??...) please check this and try again

However if everything is fine, the system responds with:

+??XXXXXXXX has successfully been added to memory

Removing a Master

Command: Master remove +??XXXXXXXX (Follow the same rules for Phone ID as for “Set Owner”)

If you try to remove the only master, the system responds with:

Cannot delete the only master; if you would like to change masters add the new one before removing the old

If the number sent is not currently on the list, the system responds with:

+??XXXXXXXX is not currently on the masters list so cannot be removed, please check the number and try again

If everything is ok, the system responds with:

+??XXXXXXXX has been removed from the masters list

Get a list of all the Masters

Command: Master list

If there are less than 11 masters currently on the list, the system responds with:

Current masters numbers are +??XXXXXXXX +??XXXXXXXX ... (up to 11 numbers)

If there are more than 11 masters, then two text messages are sent. The first is:

There are too many numbers to display in one txt, a second txt will be sent showing up to the first twelve, please remove any unnecessary numbers

Followed by:

+??XXXXXXXX +??XXXXXXXX +??XXXXXXXX ... (up to 12 numbers)

Turn all Text's OFF and Disable Inputs

Command: Alerts off

The system responds with: **Alerts Disabled**

Turn all Text's ON and Enable Inputs

Command: Alerts on

The system responds with: **Alerts enabled**

Resetting the Unit

Command: Reset

The system responds with: **Module is now Resetting**

Get a list of the Inputs

Command: Input status

If the combined length of the message is less than 160 characters, the system responds with:

Currently, input1 is ON, input2 is OFF ...etc

If the combined length of the message is greater than 160 characters then two messages are sent. The first is:

Pt1/2: Currently, input1 is ON,, input4 is OFF

Followed by:

Pt2/2: input5 is OFF,, input8 is ON

If the # symbol precedes the Input name, this indicates that it is a Latch Input. And if The -L appears after the name this indicates the Input is currently in a latched state.

E.g. **#input2** is OFF-L which means that input2 is a latched Input and is in the latched state.

E.g. **#input2** is OFF which means that input2 is a latched Input and is NOT in the latched state.

Get a list of the Outputs

Command: Output status

The system responds with:

Currently, output1 is ON,, output4 is OFF

Check the Power Supply Voltage (SMS-8 uses vessel battery power)

Command: Voltage status

The system responds with: (where battery is the default name)

Battery is currently XX.XX volts

Naming Inputs and Outputs and Changing Names:

Command for initial Naming or changing name of Input or Output:

Command:

Change Current Input or Output Name to New Input or Output Name
(Example: Change input3 to Bilge Pump)

This command is used to change Inputs and Outputs to a new name. Names can be multiple words up to a total length of 25 characters including spaces. Once the name has been changed, the particular Input or Output is always referred to by the new name (Eg: Bilge Pump). For commands or status interrogation and the SMS-8 will respond using the new name. Use table on page 17 to record your new Input and Output names.

If the device you are trying to rename is not currently in the list, the system responds with:

Sorry either that device does not exist or the message format is not understood, please check the spelling and try again

If the new name chosen does not fulfill the requirements of a name, the system responds with:

Sorry that name is not allowed, please check that it is not currently in use and that it is between 1 and 25 characters long including spaces

If everything is ok, the system responds with:

XXXXX has been renamed to YYYYYY

Turn an Output ON or OFF

Command: Turn OUTPUT NAME on (or) off (Example: Turn Refrig on)

This command is used to turn on/off Outputs. If the item named is not an Output, the system responds with:

Sorry OUTPUT NAME is not an Output, please check the name and try again
If the message has any option, other than on or off, the system responds with:

Sorry that is not a valid command; options are either "on" or "off"

Or

If everything is fine, the system responds with:

OUTPUT NAME has been turned off (or) on

Change the Input Delays

Command: Change INPUT NAME delay to YYY
(Example: Change input1 delay to 10min)

Where YYY can be one of the following 100ms (minimum delay time), 5sec, 15sec, 1min, 10min or 15min. If the user tries to change the delay of an Output, the system responds with:

Delays do not apply to outputs, please check the device name and try again

If YYY is not a valid option, the system responds with:

Sorry that delay time is not recognized; valid options are 1sec, 5sec, 15sec, 1min, 10min, and 15min and must be one word as shown here

Otherwise the system responds with:

INPUT NAME delay has been changed to YYY

Change Input to Normally Open or Normally Closed

Command: Make INPUT NAME active open (or) closed
(Example: Make Shore Power Active closed)

This command is used to define if the switch wired to the Input is normally open or closed. The Input defaults are set for a normally open switch (which is active closed). That is, the Input becomes active when the switch is closed.

Active closed means: the Input switch is normally open and goes closed to activate Input.

Active open means: the Input switch is normally closed and goes open to activate Input.

The system responds with:

INPUT NAME will now become active on (!!!!!!!!!!!!!!!) transitions

OR: if you try to set it for its current setting, the system responds with:

INPUT NAME is all ready set for (!!!!!!!!!!!!!!!) transitions and does not need changing

Set an Input as a latched Input

Command: Make INPUT NAME latching
(Example: Make Motion Detector latching)

This sets the Input to a latched Input.

If an Input changes state the system responds with:

INPUT NAME has been turned on and is latched

Set an Input as a Non-latched Input

Command: Make INPUT NAME nonlatching
(Example: Make Motion Detector non-latching)

This sets the Input to a NON latched Input and the system responds with:

INPUT NAME is no longer a latching input

Reset a latched Input (used to return Input to “non-activated” state)

Command: Reset **INPUT NAME** (Example: Reset Motion Detector)

The system responds with:

INPUT NAME is no longer in a latched state and will begin to be monitored again

If **INPUT NAME** is not an Input, the system responds with:

Latch states only apply to Inputs, please double check the name and try again

If the latch for that Input is not currently set, the system responds with:

INPUT NAME latch is not currently set so does not need clearing

Link an Input to an Output

Command: Link **INPUT NAME** to **OUTPUT NAME**
(Example: Link Motion Detector to Alarm Horn)

to clear a link

Clear INPUT NAME link (Example: Clear Motion Detector link)

The system responds with:

INPUT NAME has successfully been linked with **OUTPUT NAME**

Function: If a link is setup between an Input and an Output and the Input is turned ON, the Output will also turn on. Full control of the Output is still available (see page 11).

Make an Output pulse On and Off

Command: Make **OUTPUT NAME** pulse (Example: Make Gen Start pulse)

When the Output ON command is sent as follows:

Turn **OUTPUT NAME** On

The Output will turn On for a minimum of 3 seconds (max 12 sec's) and then turn Off, the system responds with:

OUTPUT NAME has been pulsed on and off

If you try and set an Input as a pulse Output, the system responds with:

Sorry pulses only apply to outputs, please check the name and try again

If the Output is already a pulsed Output the system responds with:

OUTPUT NAME is already a pulsed output so does not need changing

If the Output is initially off and everything goes correct, the system responds with:

OUTPUT NAME is now a pulsing output

Make an Output pulse On and Off (continued)

If the Output was initially On when the Output was set, the system responds with:

OUTPUT NAME is now a pulsing output and has been turned off in preparation of use

If the Output is linked to an Input, when the Input is triggered the system sends:

The input **INPUT NAME** has turned on

After the pulse has completed the system then sends a second txt with:

INPUT NAME linked output OUTPUT NAME has been pulsed on then off

Clear Output pulse (set back to non pulsed)

Command: Clear OUTPUT NAME pulse (Example: Clear Gen Set Pulse)

If you try to clear a pulsed Output when it is not set, the system responds with:

OUTPUT NAME is not currently a pulsed output so does not need changing

If you try and clear a pulse on an Input, the system responds with:

Sorry pulse only apply to outputs, please check the name and try again

Otherwise if its all ok, the system responds with:

OUTPUT NAME is no longer a pulsing output

Change Battery Alarm from 11.5 volts to 22.5 volts or vice versa

Command: Change battery voltage to XXXX

Where XXXX can be either 11.5volts or 22.5volts (Default = 11.5volts).

If the selected voltage level is not one of these options, the system responds with:

Sorry that voltage is not recognized; valid options are 11.5volts and 22.5volts and must be one word as shown here

Otherwise the system responds with:

Battery voltage has been changed to XXXX

This system monitors the battery by calculating the average value of the supplied voltage over the previous 2 - 5 minute period. Once this average has been detected to be below the set value for the set time (defaults are 11.5volts and 1min) it sends a text message to inform the owner. The inclusion of the running average helps protect the system from detecting inaccurate readings during periods of increased load.

Reset Battery Alarm

Command: Reset battery alarm

This command is used to clear the Low Battery Voltage alarm, after it has alerted the owner that the voltage has dropped below the set level (where battery is the default name).

If the alarm is not currently set, the system responds with:

Battery alarm is not currently active and does not need to be cleared

Otherwise the system responds with:

Battery alarm has been cleared and will begin to be monitored again

Get Firmware Version

Command: System info

The system responds with: **SMS Controller SV: 4.9**

Reset Unit to Factory Defaults

Command: Clear device memory +??XXXXXXXXXX (Owner mobile number – see page 8)

The unit responds with:

The device memory has been returned to the default values, the system will now restart

CONDITIONS OF WARRANTY

Smart Switch Technologies Ltd (the manufacturer) warrants that all of its products are free of defects. Any apparent fault will be rectified free of charge by Smart Switch Technologies Ltd for a period of 12 months from purchase date, provided that:

- ❑ All costs of installation, cartage, freight, travelling expenses and insurance are paid by the customer
- ❑ The liability of Smart Switch Technologies Ltd under these Conditions Of Warranty is limited to any defective components or workmanship directly attributed to the manufacture of this product
- ❑ The manufacturer's liability under this warranty is limited to the replacement of defective parts (or at our option, replace) without charge where determined by the manufacturer
- ❑ Where a replacement unit is provided the manufacturer is entitled to and will retain the replaced product as its property
- ❑ The equipment has been installed correctly and is used in accordance with the instructions issued with the product

In no event will Smart Switch Technologies Ltd or its agents accept any liability for any direct, indirect or consequential losses or damages whatsoever or howsoever arising from the use of the product.

Where conditions or warranties are implied or other rights are given in respect of these Conditions Of Warranty under the Trade Practices Act or any other laws they are, to the extent permitted by such laws, excluded. Where such conditions, warranties or rights are not able to be excluded, Smart Switch Technologies Ltd liability for any breach of any such condition or warranty shall, to the extent permitted by such laws, be limited to the repair or replacement of the equipment. These conditions may only be varied with the written approval of the directors of Smart Switch Technologies Ltd.

Appendix One: Record Your Names for all Inputs and Outputs

Input	Default Name	[Name] (Up to 25 characters – including spaces)	Latched Yes No	Linked to	Active Open or Closed
1	input1				
2	input2				
3	input3				
4	input4				
5	input5				
6	input6				
7	input7				
8	input8				
Output					
1	output1				
2	output2				
3	output3				
4	output4				

Trouble Shooting Guide

PROBLEM	CAUSE	POSSIBLE SOLUTION
LED not flashing	No power	Check power supply
LED fast flashes (every 1 second) and never slow flashes (every 3 seconds)	Cannot find the GSM network	<ol style="list-style-type: none"> 1. Replace aerial with high gain aerial 2. Move unit to different location 3. SIM card not installed
LED slow flashes (every 3 seconds) But no texts are sent or received	The unit can find the GSM network (hence the slow flashes) but the signal strength is to low	<ol style="list-style-type: none"> 1. Replace aerial with high gain aerial 2. Move unit to different location 3. SIM card NOT registered with the network provider 4. No credit on the SIM card

Appendix Two: SMS-8 Application Notes

Simple Shore Power Monitoring

An inexpensive and effective means to monitor your vessel's shore power connection is to purchase a 12v DC power supply as typically used to power cordless phones or video games - the type normally available at retailers and electronics suppliers. This unit is plugged into a conveniently located 120/240v AC outlet on-board your vessel and wired as shown in the diagram below (fig. 1). Name this Input **Shore Power** using the Command on page 11. If shore power is lost, the SMS-8 will send a text message to all "Masters" saying "**Shore Power** has turned off". To avoid any nuisance text message's caused by a tripped breaker, or someone temporarily using your power outlet, you should set a delay for this Input (a 15 minute delay is appropriate for most situations). To set the delay, simply send a text command "Change **Shore Power** delay to 15min" as shown on page 12.

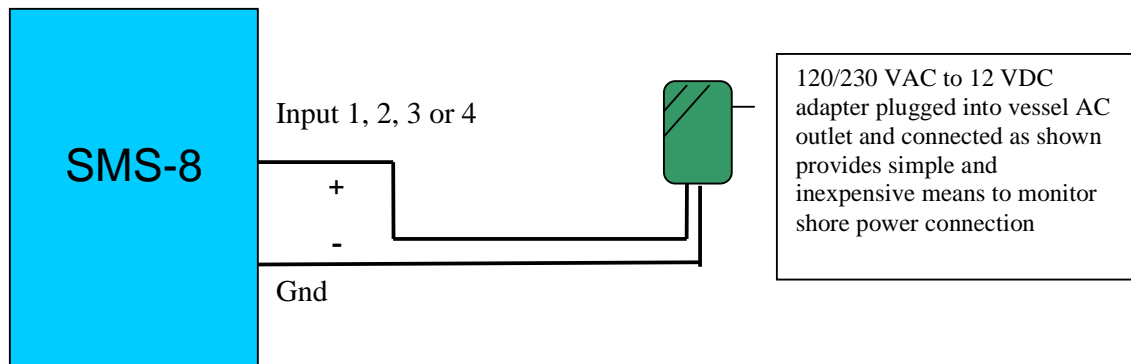

Figure 1

Fixed Wiring Shore Power Monitoring (requires a registered electrician)

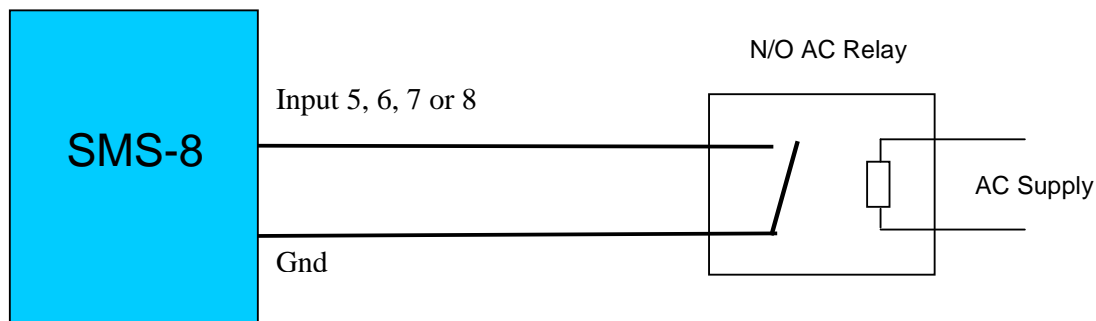

Figure 2

! Important Note !

A registered electrician must be used when connecting to the mains supply voltage.

Intruder Alarm Systems

The following configurations define possible solutions for intruder alarms. Like all other alerts provided by the *Yacht-Guard* SMS-8, these should be disabled prior to your coming on-board your vessel. This is easily accomplished by issuing the text command: **Alerts off** When leaving the vessel, simply issue the text command: **Alerts on**

Connecting to a PIR motion sensor

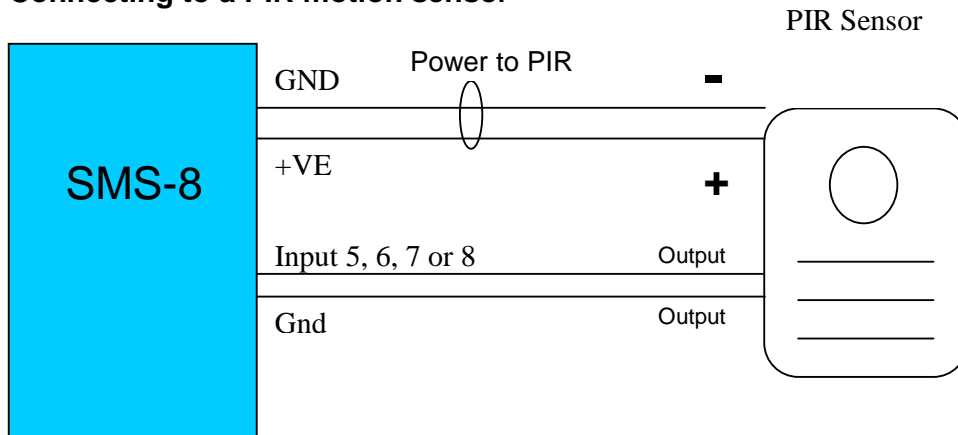

Commands

Send command text: Change input? to **Sensor**

Send command text: Make **Sensor** latching

Send command text: Make **Sensor** active open (most PIR are normally closed and go open when activated)

When the unit detects movement you will receive the following text message:

“The input **Sensor** has been turned on and is now latched”

When the alarm has been triggered you can reset it by sending the txt: **Reset Sensor**

If you want to connect a siren and/or flashing light to output1 then:

Send command text: Link **Sensor** to output1

Send command text: Change output1 to **Siren**

When the unit detects movement you will receive a text message and the siren and/or flashing light will turn On.

“The input **Sensor** has been turned on and is now latched. Linked output **Siren** has also been turned on”

When the alarm has been triggered you can reset it by sending the txt: **Reset Sensor or the siren can be turned off by sending the command: **Turn siren off****

Note: The command: **Reset sensor** will still need to be sent to reset the system even though the siren has been turned off (to unlatch the sensor Input).

Door and Window Alarms

Alarms sensors for doors and windows generally consist of magnetically held switches. The contacts are normally-closed (NC). If a door/window is opened the circuit is opened generating an alarm. An alarm is also generated if the wire is cut between the sensor and the monitoring system opening the circuit. This prevents an intruder from defeating the alarm system by merely cutting a wire. The wiring diagram for the window/door switches is similar to the motion detector and the same basic commands are used to set up the motion detector.

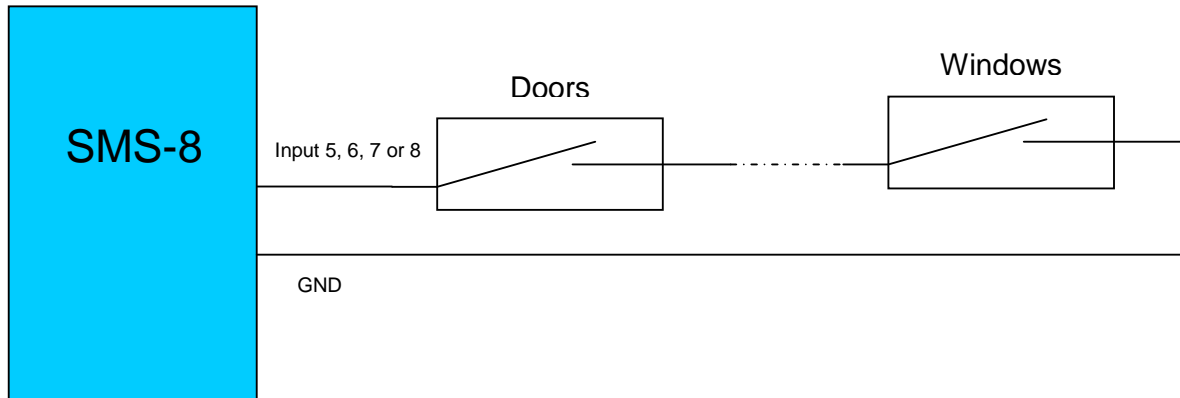

Send command text: Change input? to **Door Sensor**

Send command text: Make **Door Sensor** latching

Send command text: Make **Door Sensor** active open (sensors are normally closed and go open when activated)

When the unit detects movement you will receive the following text message:

“The input **Door Sensor** has been turned on and is now latched”

When the alarm has been triggered you can reset it by sending the txt: **Reset Door Sensor**

If you want to connect a siren and/or flashing light to output1 then:

Send command text: Link **Door Sensor** to output1

Send command text: Change output1 to **Siren**

When the unit detects an intruder you will receive a text message and the siren and/or flashing light will turn On.

“The input **Door Sensor** has been turned on and is now latched. Linked output **Siren** has also been turned on”

When the alarm has been triggered you can reset it by sending the txt: **Reset Door Sensor or the siren can be turned off by sending the command: **Turn Siren off****

Note: The command: Reset **Door Sensor** will still need to be sent to reset the system even though the siren has been turned off.

©

All technologies, design and Intellectual property is owned by
Penguin Electronics Ltd
New Zealand
Version 4.9